

رہی تعلیم مشرق میں، نہ مغرب میں رہی غیرت
یہ جتنے پڑھتے جاتے ہیں، جہالت بڑھتی جاتی ہے!

PHY301-Final Term
Subjective Questions from
Past Papers Solved
with References
By Masoom Fairy

PHY301-Final Term
Subjective Questions from
Past Papers Solved
with References
By Masoom Fairy

Final Term Examination

Fall 2012

Phy301-Circuit Theory

1. State kirchhoff's current law (KCL)

Marks: 2:

Answer: (PAGE 42)

KIRCHHOF'S CURRENT LAW

Sum of all the currents entering in the node is equal to sum of currents leaving the node. It can also be defined as

$$\text{sum of entering currents} + \text{sum of leaving currents} = 0$$

2. If we want to find V_{out} by superposition, what type of replacement we will do with voltage and current source? Just draw the diagrams.

Answer: (PAGE 92)

“ In any linear circuit containing multiple sources, the current or voltage at any point in the circuit may be calculated as the algebraic sum of the individual contributions of each source acting alone.”

When determining the contributions due to independent sources, any remaining current sources are made zero by replacing them by open circuit and any voltage sources are made zero by replacing them by short circuit.

3. State the superposition theorem.

Answer: (PAGE 92)

The principle of superposition, which provides us with the ability to reduce a complicated problem

to several easier problems – each containing only a single independent source – states that

“ In any linear circuit containing multiple sources, the current or voltage at any point in the circuit may be calculated as the algebraic sum of the individual contributions of each source acting alone.”

**PHY301-Final Term
Subjective Questions from
Past Papers Solved
with References
By Masoom Fairy**

When determining the contributions due to independent sources, any remaining current sources are made zero by replacing them by open circuit and any voltage sources are made zero by replacing them by short circuit.

4. Forward biased or reversed biased diode.

Answer: (PAGE 124 & 125)

THE FORWARD BIASED PN-JUNCTION (DIODE)

When positive terminal of a battery is connected to the anode or P-side and negative terminal to the cathode or to the N-side of a diode (PN-junction), the diode is said to be **FORWARD-BIASED**.

In the figures to follow it may be noted that the arrow points to the more negative potential in each case. In **fig. a** below the positive terminal of a battery through a resistor is connected to the anode whereas the cathode is attached to the neutral terminal and now the condition of the forward biased is fulfilled. In **fig. b** below the negative terminal of a battery is connected to the cathode whereas the anode is attached through a resistor to the neutral terminal and now the condition of the forward biased is fulfilled where I_F shows the forward conventional current.

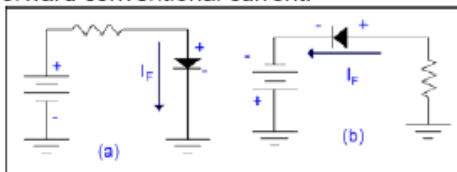

In **fig. c** below the positive volts has been applied to the anode of the diode through a resistance and cathode terminal of the diode is connected to the neutral terminal through resistance which will fulfill the condition of forward biased. Where I_F shows the forward conventional current.

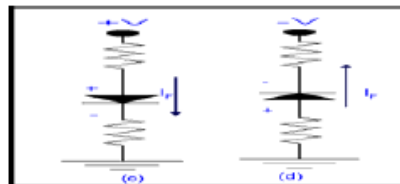

In **fig. d** above the -ve volts has been applied to the cathode of the diode through a resistance and anode terminal of the diode is connected to the neutral terminal through resistance which will fulfill the condition of forward biased. Where I_F shows the forward conventional current will be establish in the diode.

PHY301-Final Term
Subjective Questions from
Past Papers Solved
with References
By Masoom Fairy

THE REVERSE - BIASED PN-JUNCTION (DIODE)

When positive terminal of a battery is connected to the cathode or N-side and negative terminal to the anode or to the P-side of a diode (PN-junction), the diode is said to be **REVERSED - BIASED**.

A PN-junction diode is reverse biased when the n type material (cathode) is more positive than the p type material (anode). This causes the depletion region to widen and prevent current. A diode will not conduct when the arrow points to the more positive of the diode potentials.

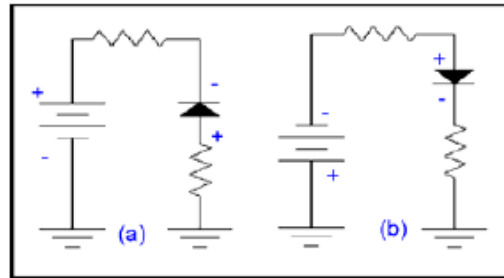

In **fig. a** the negative of the battery is connected to the anode through a resistor and positive terminal of the battery is connected the cathode therefore no current will flow and we can say that diode is not existing and it will act as an open circuit.

PHY301-Final Term
Subjective Questions from
Past Papers Solved
with References
By Masoom Fairy

In **fig. b** the negative terminal of the battery is connected to the anode through a resistor and positive terminal of the battery is connected the cathode.

The reverse – biased diode behaves opposite to the forward-biased diode. This means in case of a reverse-biased diode , majority carrier current does not flow and instead of that only minority carrier current can flow. Moreover, the depletion charge layer will expand or enlarged compared to the forwar –biased diode where the depletion charge layer shrinks, so it will act as an open circuit.

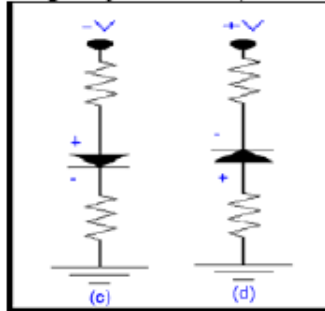

In **fig. c** the negative voltage has been applied to the anode of the diode through a resistance and cathode terminal of the diode is connected to the neutral terminal through resistance. Which will fulfill the condition of reversed biased.

In **fig. d** the positive voltage has been applied to the cathode of the diode through a resistance and anode terminal of the diode is connected to the neutral terminal through resistance. Which will fulfill the condition of reversed biased

Here we can say that the reverse-biased PN-junction can't support majority carrier current but it will allow the minority carrier current to flow across the junction. This minority carrier current is called as reverse current and is much smaller than the forward majority carrier current of the forward biased PN junction.

5. Differentiate between half wave and full wave rectifier.

Answer:

The difference between a half wave rectifier and and full wave rectifier is that a half wave rectifier removes one of the positive or the negative half cycle of the wave and only either half of the cycle appears in the output whereas in the full wave rectifier both the cycles appear in the positive or negative cycle of the output.

The efficiency of a full wave rectifier (81.2%) is too double of a half wave rectifier(40.6%) because the r.m.s. value in case of a full wave rectifier is Maximum current divided by 1.41

PHY301-Final Term
Subjective Questions from
Past Papers Solved
with References
By Masoom Fairy

(under root of 2) whereas in case of a half wave rectifier the r.m.s current is half of maximum current during the wave cycle.

<http://www.indiastudychannel.com/experts/18455-what-Differences-between-half-wave-full-wave.aspx>

OR

Half Wave Rectifier: A half wave rectifier is a special case of a clipper. In half wave rectification, either the positive or negative half of the AC wave is passed easily, while the other half is blocked, depending on the polarity of the rectifier. Because only one half of the input waveform reaches the output, it is very inefficient if used for power transfer. Half-wave rectification can be achieved with a single diode in a one phase supply.

Full Wave Rectifier: A full-wave rectifier converts the whole of the input waveform to one of constant polarity (positive or negative) at its output. Full-wave rectification converts both polarities of the input waveform to DC (direct current), and is more efficient. However, in a circuit with a non-center tapped transformer, four diodes are required instead of the one needed for half-wave rectification.

(From other past papers)

6. Conduction band and valence band.

Answer:

Valence band: <http://www.answers.com/topic/valence-band>

Valence band is the highest range of electron energies in which the electrons are normally present at absolute zero temperature.

Conduction band: http://en.wikipedia.org/wiki/Conduction_band

This is the range of electron energies enough to free an electron from binding with its atom to move freely within the atomic lattice of the material.

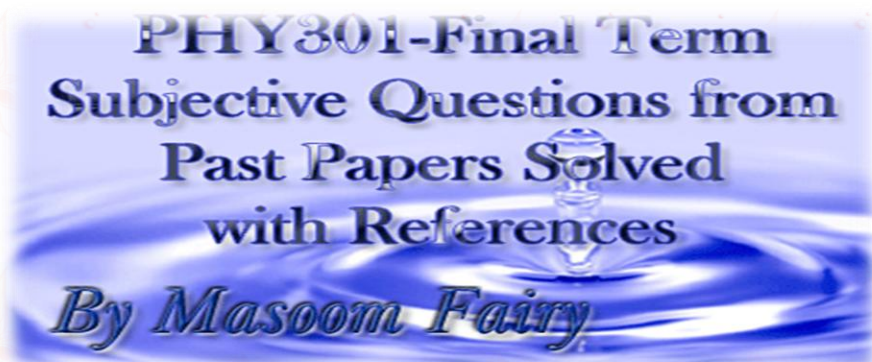



7. Why is electron flow with the arrow in the symbol of a Zener diode instead of against the arrow as it is in a normal diode?

Answer:

Because Zener diodes are operated in the reverse bias mode.

<http://quizlet.com/15560197/navedtra-14179-chapter-3-flash-cards/>

8. What resistance property is found in tunnel diodes but not in normal diodes?

Answer:

Negative resistance is found in tunnel diodes which made them different.

<http://www.tpub.com/neets/book7/26m.htm>

9. Differentiate between Clippers & Clampers. Also write the various types of Clipper circuits and define each type.

Answer: (PAGE 160 and 161)

Clippers,

There are variety of diode networks call clippers that have the ability to clip off a portion of the input signal without distorting the remaining part of the alternating waveform. The half wave rectifier studied earlier is a simplest form of diode clipper. Depending on the orientation of the diode the positve or negative region of the input signal is clipped off.

It makes a sketch in mind about the response of the network.determine the applied voltage that causs change in the diode bise. be continuously aware of the difined terminal and porlarity of V_o . Sketch the input signal on the top and the output at the bottom to determine the output at instantaneouse pointer of the input.

Types of Clipper,

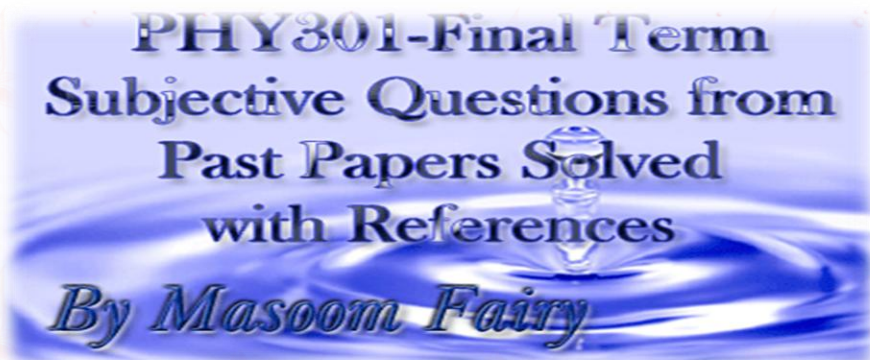

There are two general types

Series

The series is defined as one where the diode is in series with the load as half wave rectifier.

Parallel

The parallel is the one where the diode is in parallel with the load as half wave rectifier.

Clampers,

There are the circuits which clamp the input signal to a different level depending upon the configuration of the clamper circuit.

10. What is the dependence of junction area and temperature of pn junction diode on Leakage current?

Answer: (PAGE 132)

The leakage currents are proportional to the junction area, just as I_s . Its dependence on temperature is however, different from that of I_s .

Final Term Examination

Fall 2011

Phy301-Circuit Theory

1. Find the voltage drop at 4 ohms. [marks 2]

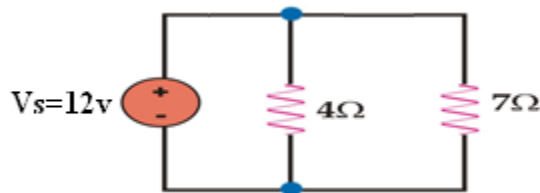

Answer: (Solved according to PAGE 32)

PHY301-Final Term
Subjective Questions from
Past Papers Solved
with References
By Masoom Fairy

The Formula is $V = R_1 * V_s / R_1 + R_2$

By putting values,

$$= 4 * 12 / 4 + 7$$

$$= 48 / 11$$

$$= 4.36 = \text{Ans.}$$

2. What would be the current across the load?

[marks3]

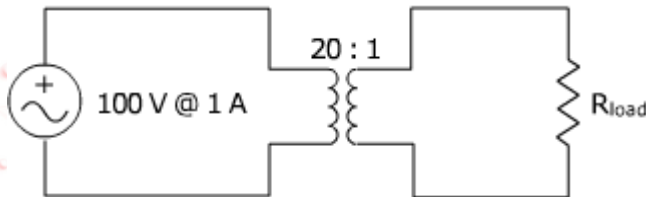

Answer:

Formula is $I_2 = N_2 / N_1 * I_1$

$$= 1 / 20 * 1 \text{ A}$$

$$= 0.05 \text{ A}$$

$$= 50 \text{ mA} = \text{Ans.}$$

3. Keeping in mind Norton's Theorem find Norton's Resistance R_N . Do not draw the circuit. Write each step of calculation.

[Marks5]

PHY301-Final Term
Subjective Questions from
Past Papers Solved
with References
By Masoom Fairy

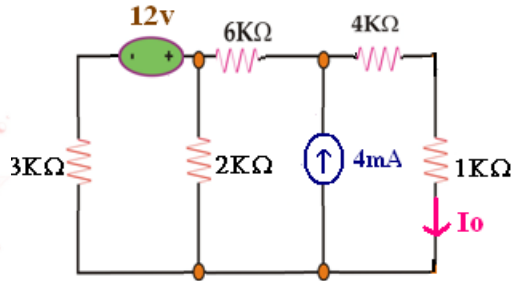

Answer:

First Step:

Remove the load resistance R_L.

Second Step:

Find I_{no} by short circuiting the open terminals of the circuit.

$$I_n = I_3 = 4\text{mA}$$

Third Step:

Find R_n by short circuiting all voltage sources.

$$3\text{k} \parallel 2\text{k} = \frac{3 \times 2}{3+2} = 1.2\text{k}$$

$$1.2\text{k} + 6\text{k} + 4\text{k} = 11.2 = \text{Ans.}$$

4. What is rectification and amplification, and what devices use rectification and amplification? [marks5]

Answer:

Rectification is the process of converting an AC signal into a DC signal. It carried out at all levels of electric power, from a thousandth of a watt to detect an AM radio signal, to thousands of kilowatts to operate heavy electric machinery.

Devices are Mobile phones, VCRs, washing machines etc.

Amplification is the process of increasing the power of the signal.

Devices are radio receivers, oscillators etc.

5. Calculate the voltage V_o by using Thevenin's theorem .

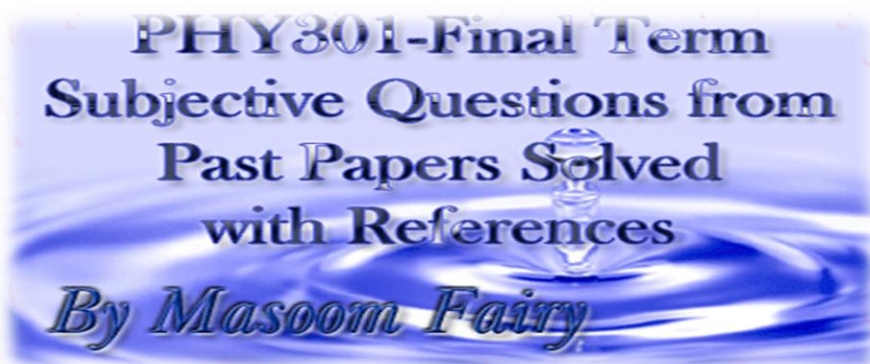

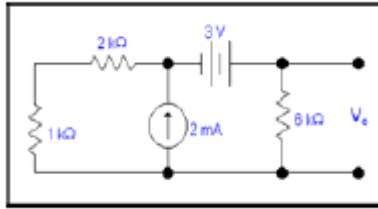

Answer: (PAGE 100 and 101)

We want to calculate V_o by using Thevenin's theorem .we will follow the steps given earlier.

First step: Removing R_L

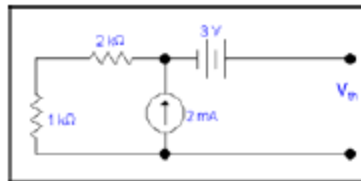

Here R_L is 6k resistor at which we want to calculate the voltage V_o .

Second step: Calculating V_{th}

1k is in series with 2k so modified circuit will be as

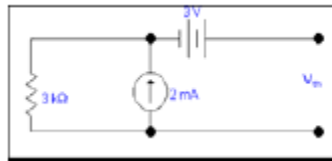

3k is in parallel with 2mA source, so by source transformation
 Now 2mA source is in parallel with 3k resistor. So it can be changed to a
 voltage source of value = $2m \times 3k$ (by ohm's Law)
 = 6 Volts.

3k resistor will become in series with this source as shown in the circuit below

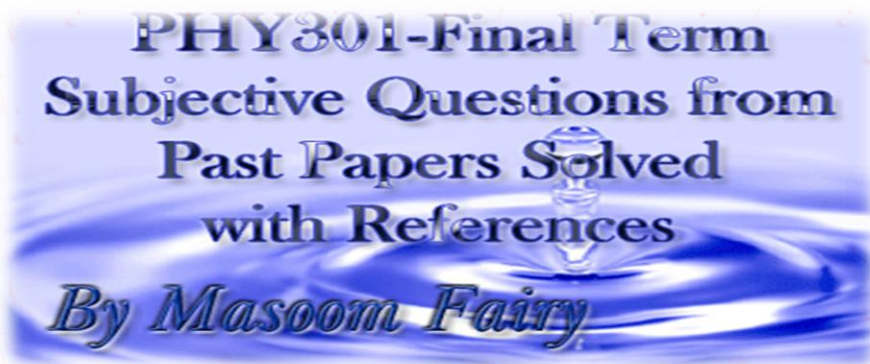



Now the combined effect of these two source will be 9 volts.



So

$$V_{th} = 9 \text{ volts}$$

Third step: Calculating R_{th}

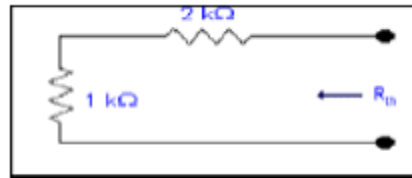

$$R_{th} = 3k$$

Fourth step: Calculating the unknown quantity.

After calculating V_{th} and R_{th} , re-inserting the load resistance R_L in the circuit in series with R_{th} and considering the V_{th} as a battery in series with these two resistances.

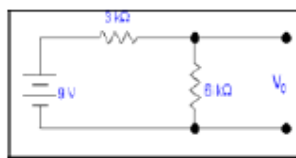

$$V_0 = (6k/9k) \times 9$$

$$V_0 = 6 \text{ volts}$$

PHY301-Final Term
Subjective Questions from
Past Papers Solved
with References
By Masoom Fairy

Final Term Examination

Fall 2011

Phy301-Circuit Theory

1. What is Zener diode? [2 marks]

Answer:

A Zener diode is a type of diode that permits current not only in the forward direction like a normal diode, but also permits in the reverse direction when the voltage is above a certain value known as the breakdown voltage, “zener knee voltage” or “zener voltage” or “avalanche point”.

http://en.wikipedia.org/wiki/Zener_diode

2. Using the **Thevenin's theorem**, what type of changes we will do in the circuit, to find Thevenin's voltage V_{th} ? No need to solve the circuit. [2 marks]

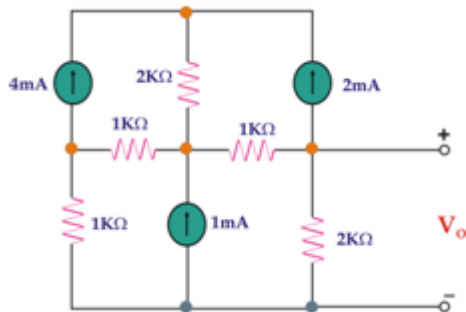

Answer: (LECTURE 25)

We perform only two steps for finding V_{th} . In first step we have to remove Load resistance which is 2k ohms then in second step we have to Calculate V_{th} by using any method at open terminals of open circuit.

3. State Kirchoff's voltage law (KVL). [2 marks]

Answer: (PAGE 58)

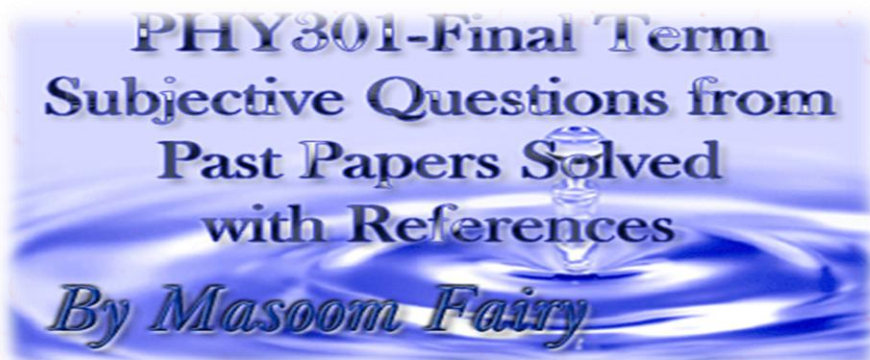

KIRCHHOFF'S VOLTAGE LAW:

This law states that the algebraic sum of the voltages around any loop is zero.

OR

Sum of voltages rises and voltage drops around any closed path or loop is equal to zero.

4. Calculate V_0 with the using KVL equation. [5 marks]

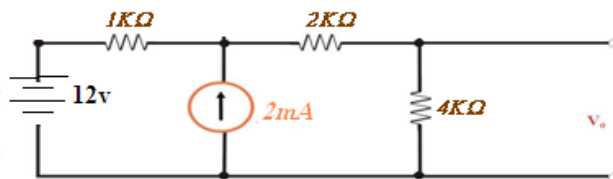

Answer:

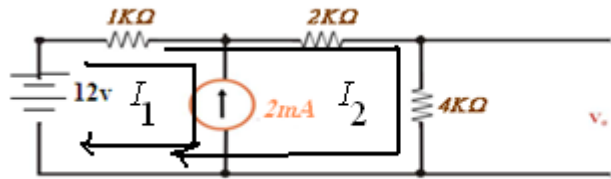

$$I_2 = -2\text{mA}$$

$$4KI_2 + 2KI_2 + 1K(I_2 + I_1) = 12$$

$$7KI_2 + 1KI_1 = 12$$

$$7KI_2 - 2 = 12$$

$$I_2 = 14/7$$

$$I_2 = 2\text{mA}$$

$$V_0 = 4k(2\text{mA})$$

$$= 8\text{volts} = \text{Ans}$$

5. Consider the circuit as shown, Write V_s eq. for AC analysis purposes. [3 marks]

PHY301-Final Term
Subjective Questions from
Past Papers Solved
with References
By Masoom Fairy

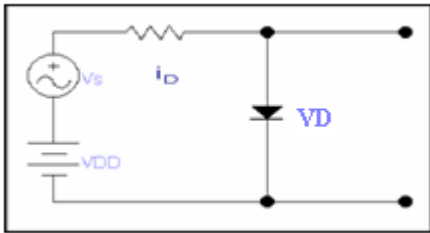

Answer:

**PHY301-Final Term
Subjective Questions from
Past Papers Solved
with References
By Masoom Fairy**

APPLICATION:

Consider the circuit as shown, for analysis purposes, we can split the circuit into two parts that is ac and dc

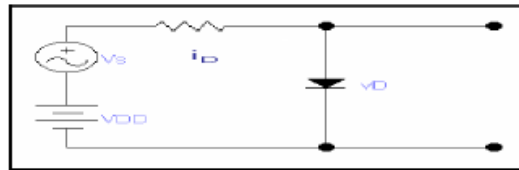

DC source having the value of VDD

we replace the ac and replace diode with constant drop model

For dc analysis the Circuit will be

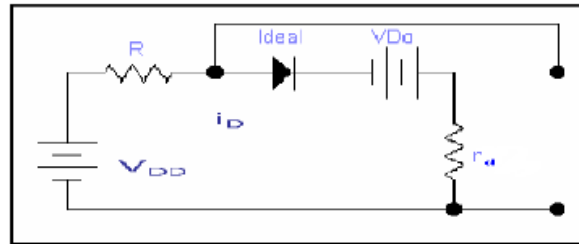

in case of DC we consider only DC current I_D is flowing and no effect of the ideal diode because this ideal diode is forward biasing and it results in short circuit therefore

From KVL

$$V_{DD} - I_D R - V_{Do} - I_D r_d = 0$$

$$V_{DD} = I_D R + V_{Do} + I_D r_d \text{ ----- (A)}$$

in case of DC only DC current I_D is flowing the

For ac analysis we will remove DC sources which are the part of the original circuit and also remove the DC source which appear in the previous effective circuit and we also remove the ideal circuit so our circuit will be as

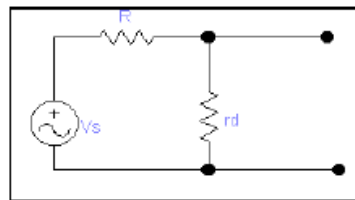

For ac analysis

$$v_s = i_d (R + r_d) \text{ ----- (B)}$$

by combining (A) and (B)

Overall analysis is

$$V_{DD} + v_s = I_D R + V_{Do} + I_D r_d + i_d (R + r_d)$$

$$= I_D (R + r_d) + i_d (R + r_d) + V_{Do}$$

$$V_{DD} + v_s = (R + r_d)(I_D + i_d) + V_{Do} \text{ ----- (C)}$$

But



$$I_D + i_d = i_D$$

therefore

$$V_{DD} + v_s = (R + r_d)(I_D + i_d) + V_{D0}$$

separating the dc and signal quantities on both sides of equation (C)

$$V_{DD} = I_D R + V_{D0}$$

which is represented by the circuit in the figure below

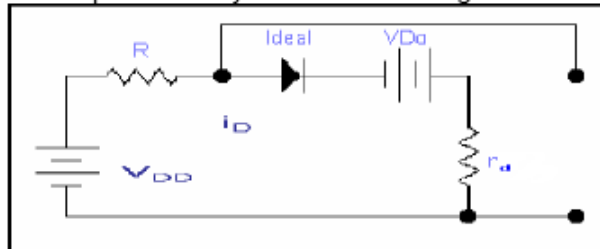

and for the signal

$$v_s = i_d (R + r_d)$$

which is represented by the circuit in the figure below

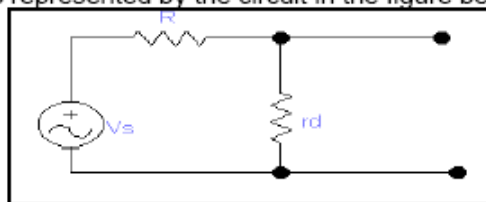

However, if we carefully see the ac equation circuit, it is nothing more than a voltage divider. Hence the diode signal voltage will be

$$V_d = V_s r_d / (r_d + R)$$

6. Describe the function of transistor. [3 marks]

Answer:

In electronics, a transistor is a semiconductor device commonly used to amplify or switch electronic signals. A transistor is made of a solid piece of a semiconductor material, with at least three terminals for connection to an external circuit. A voltage or current applied to one pair of the transistor's terminals changes the current flowing through another pair of terminals. Because the controlled power can be much larger than the controlling power, the transistor provides amplification of a signal.

<http://answers.yahoo.com/question/index?qid=20080916043112AAra3iv>

7. What is the difference between Ideal diode model and practical diode model?

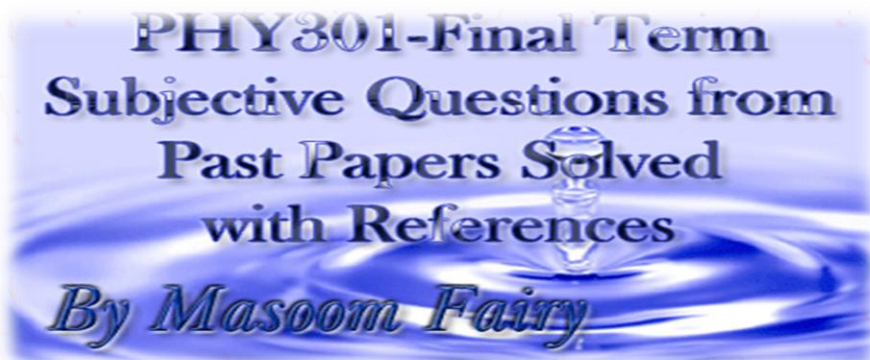

[3 marks]

Answer:

(PAGE 136)

Ideal Model:

We have seen that the diode behaves essentially as a *switch*: on when forward biased, off when reverse biased.

Figure Ba: Ideal diode model.

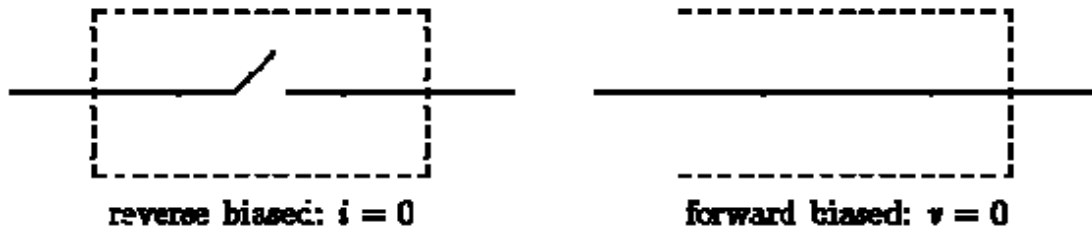

PRACTICAL MODEL:

In practice we find that there is a voltage drop of about 0.7 V across the diode (silicon; germanium is 0.3V) when it is forward biased, and so it is often useful to include this voltage drop in circuit analysis.

Figure C_a: Practical diode model.

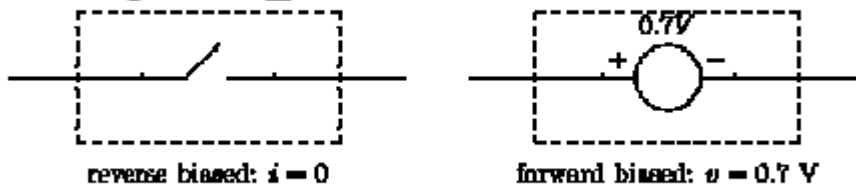

Final Term Examination

Fall 2010

Phy301-Circuit Theory

Question No: 1 (Marks: 2)

PHY301-Final Term
Subjective Questions from
Past Papers Solved
with References
By Masoom Fairy

In the NPN transistor, what section is made very thin compared with the other two sections? (Marks: 2)

Answer: (PAGE 175)

The base layer is very thin as compared to other two, normally in the range of 150:1.

Question No: 32 (Marks: 2)

In a reverse biased PN-junction, which current carriers cause leakage current?

Answer: (Video Lecture 30)

Doping current carriers cause leakage current.

Question No: 33 (Marks: 2)

Sketch the shape of the output voltage waveform for this "clipper" circuit, assuming an ideal diode with no forward voltage drop:

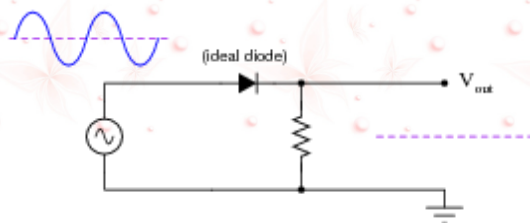

**PHY301-Final Term
Subjective Questions from
Past Papers Solved
with References
By Masoom Fairy**

Answer: (Not conform)

It will be step sin wave or half sin wave or half wave

Question No: 34 (Marks: 3)

Find the value of I_E for transistor if $I_B = 1.5\text{mA}$ and $I_C = 4\text{mA}$

Answer: (Lecture 44)

$$I_e = I_b + I_c$$

$$\text{So, } 1.5 + 4 = 5.5 = \text{Ans.}$$

Question No: 35 (Marks: 3)

What would be the current across the load?

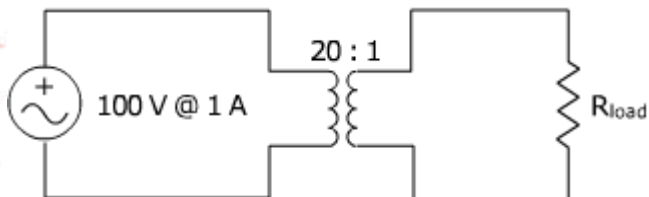

**PHY301-Final Term
Subjective Questions from
Past Papers Solved
with References
By Masoom Fairy**

Answer: (REPEATED)

$$\begin{aligned} \text{Formula is } I_2 &= N_2/N_1 * I_1 \\ &= 1/20 * 1\text{A} \\ &= 0.05\text{A} \\ &= 50\text{mA} = \text{Ans.} \end{aligned}$$

Question No: 36 (Marks: 3)

Keeping in mind **Norton's Theorem** find Norton's Resistance R_N . Do not draw the circuit. Write each step of calculation.

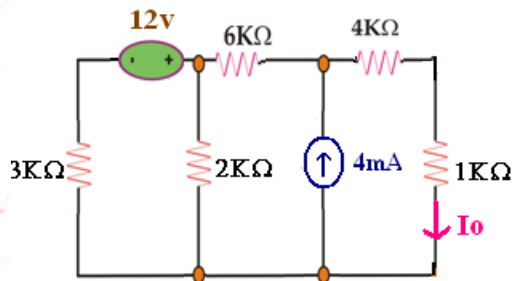

Answer: (REPEATED)

First Step:

Remove the load resistance R_L .

Second Step:

Find I_{in} by short circuiting the open terminals of the circuit.

$$I_n = I_3 = 4\text{mA}$$

Third Step:

Find R_n by short circuiting all voltage sources.

$$3\text{k} || 2\text{k} = 3 * 2 / 3 + 2 = 1.2\text{k}$$

PHY301-Final Term
Subjective Questions from
Past Papers Solved
with References
By Masoom Fairy

$$1.2k+6k+4k = 11.2 = \text{Ans.}$$

Question No: 37 (Marks: 5)

Predict how the operation of this clipper circuit will be affected as a result of the following faults. Consider each fault independently (i.e. one at a time, no multiple faults):

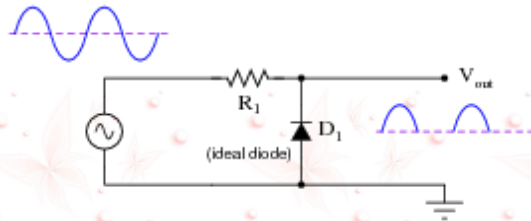

- a) Diode D_1 fails open:
- b) Diode D_1 fails shorted:
- c) Resistor R_1 fails open:
- d) Resistor R_1 fails shorted:

For each of these conditions, explain *why* the resulting effects will occur.

Answer:

Question No: 38 (Marks: 5)

At what load resistance value will this voltage regulator circuit begin to lose its ability to regulate voltage? Also, determine whether the voltage regulation is lost for load resistance values greater than this threshold value, or less than this threshold value.

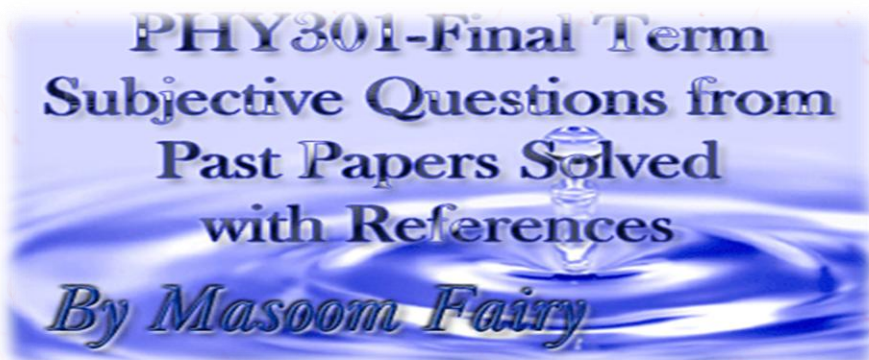

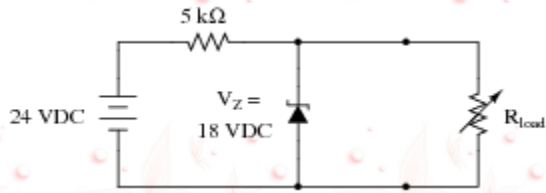

Answer:

Question No: 39 (Marks: 5)

Find I_x by **Norton's Theorem** if **Norton's Resistance R_N** is $5k\Omega$ and **Norton's current I_{Nor}** is $6mA$, draw the **Norton's equivalent** circuit.

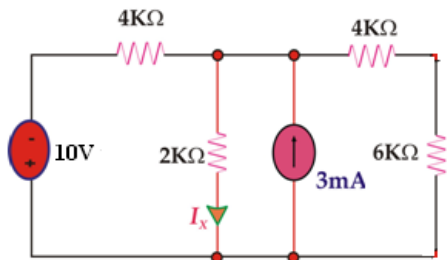

Answer:

Norton's equivalent circuit,

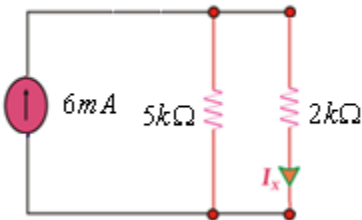

$$I_x = R_2 * I_t / R_1 + R_2$$

PHY301-Final Term
Subjective Questions from
Past Papers Solved
with References
By Masoom Fairy

$$= 5k \cdot 6 / 2k + 5k = 30/7 = 4.28 = \text{Ans.}$$

Final Term Examination

Fall 2009

Phy301-Circuit Theory

Question No: 1 (Marks: 3)

A small light bulb with a resistance of 25Ω is connected across the same 220 volt power line. How much is the current 'I'.

Answer:

$$R=25 \Omega, V=220 V$$

From ohm law $V=IR$,

$$I=V/R \text{ So,}$$

$$I=220/25=8.8 \text{ Ampere =Ans.}$$

Question No: 2 (Marks: 3)

Describe Source Transformation method for simplifying circuit.

Answer:

(PAGE 95)

Source Transformation: If we have any source embedded within a network, say this source is a current source having a value I & there exists a resistance having a value R , in parallel to it. We can replace it with a voltage source of value $V=IR$ in series with same resistance R . The reverse is also true that is a voltage source V , in series with a resistance R can be replaced by a current source having a value $I= V/R$ in parallel to the resistance R . Parameters within circuit, for example an output voltage remain unchanged under these transformations.

Question No: 3 (Marks: 3)

Given below are two figures (a) and (b) having Diode, which diode is forward biased or reversed biased, tell reason.

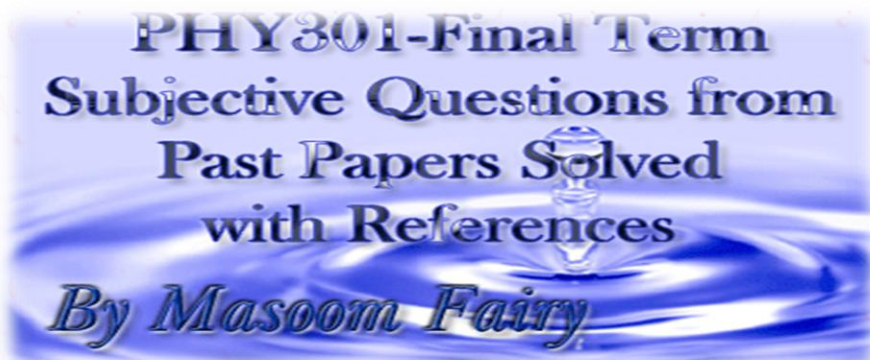

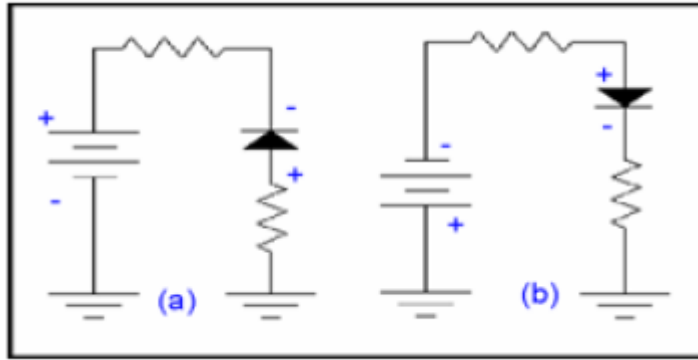

Answer: (PAGE 124)
Both A and B are reversed biased.

In **fig. a**, the negative of the battery is connected to the anode through a resistor and positive terminal of the battery is connected the cathode therefore no current will flow and we can say that diode is not existing and it will act as an open circuit. In **fig. b** the negative terminal of the battery is connected to the anode through a resistor and positive terminal of the battery is connected the cathode.

Question No: 4 (Marks: 3)

Crude logic gates circuits may be constructed out of nothing but diodes and resistors. Take for example this logic gate circuit:

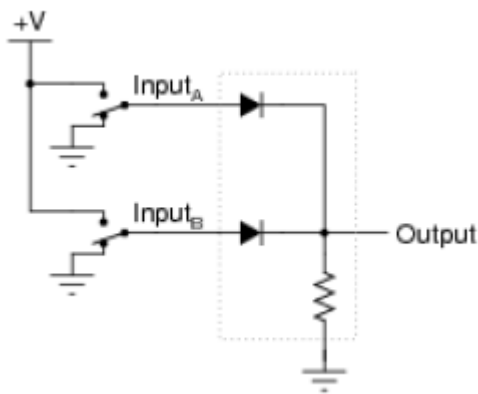

Identify what type of logic function is represented by this gate circuit.

PHY301-Final Term
Subjective Questions from
Past Papers Solved
with References
By Masoom Fairy

Answer:

This is an OR gate circuit.

If two diode OR logic gates are cascaded, they behave as current-sourcing logic gates: if the first gate produces high output voltage, the second gate consumes current from the first one. If the first gate produces low output voltage, the second gate does not inject current into the output of the first one. A diode OR gate does not use its own power supply. The input sources with high voltage supply the load through the forward-biased diodes.

http://en.wikipedia.org/wiki/Diode_logic#Diode_logic_gate_versions

Question No: 5 (Marks: 3)

Differentiate between Half wave & Full Wave Rectifier.

Answer: (Repeated)

The difference between a half wave rectifier and a full wave rectifier is that a half wave rectifier removes one of the positive or the negative half cycle of the wave and only either half of the cycle appears in the output whereas in the full wave rectifier both the cycles appear in the positive or negative cycle of the output.

The efficiency of a full wave rectifier (81.2%) is too double of a half wave rectifier (40.6%) because the r.m.s. value in case of a full wave rectifier is Maximum current divided by 1.41 (under root of 2) whereas in case of a half wave rectifier the r.m.s current is half of maximum current during the wave cycle.

<http://www.indiastudychannel.com/experts/18455-what-Differences-between-half-wave-full-wave.aspx>

OR

Half Wave Rectifier: A half wave rectifier is a special case of a clipper. In half wave rectification, either the positive or negative half of the AC wave is passed easily, while the other half is blocked, depending on the polarity of the rectifier. Because only one half of the input waveform reaches the output, it is very inefficient if used for power transfer. Half-wave rectification can be achieved with a single diode in a one phase supply.

Full Wave Rectifier: A full-wave rectifier converts the whole of the input waveform to one of constant polarity (positive or negative) at its output. Full-wave rectification converts both polarities of the input waveform to DC (direct current), and is more efficient. However, in a

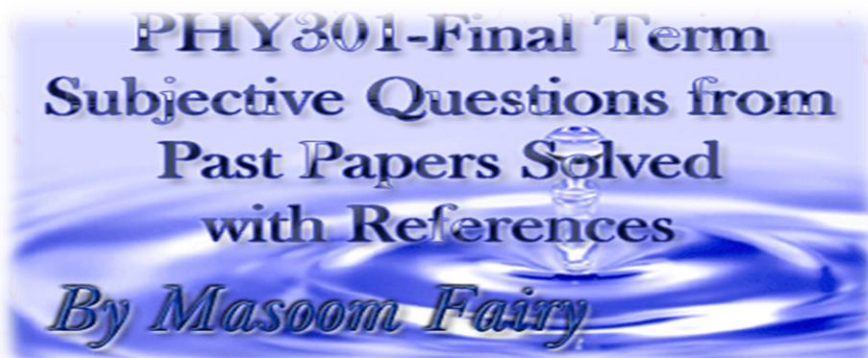

circuit with a non-center tapped transformer, four diodes are required instead of the one needed for half-wave rectification.

(From other past papers)

Question No: 6 (Marks: 5)

Keeping in mind the **Source transformation method**, how we will convert **10v** voltage source into current source and **1mA** into voltage source in the following circuit, Draw diagrams of converted circuit.

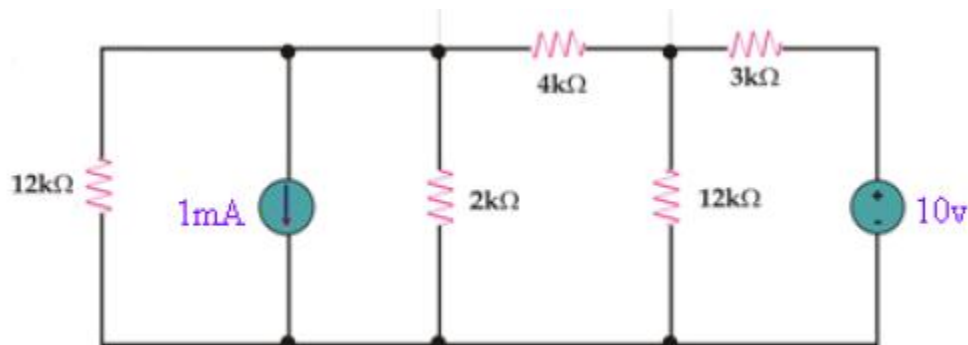

Answer:

Source transformation method: $I = V/R$

$$= 10/3k = 3.33$$

Then, $V = IR$

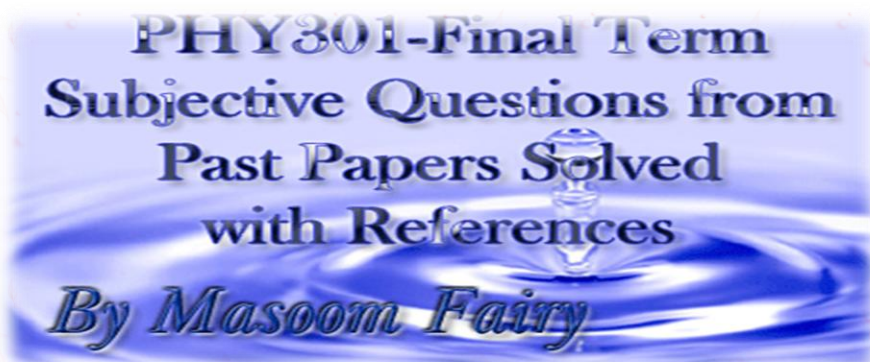

$$= -1\text{mA} * 12\text{k} = -12\text{v}$$

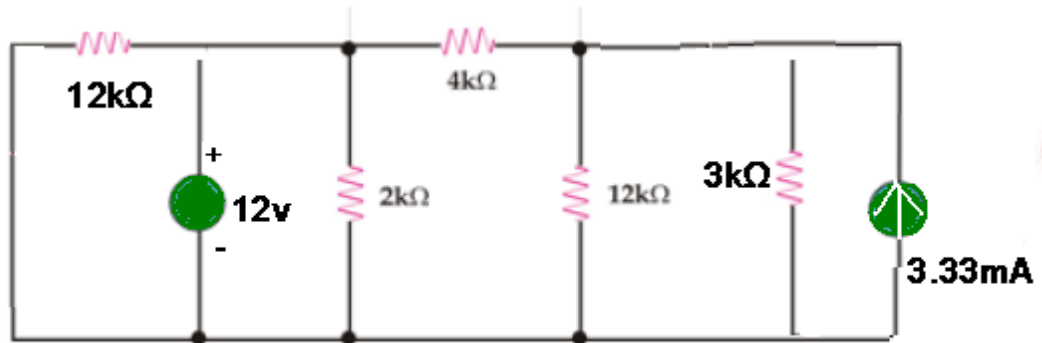

Question No: 7 (Marks: 5)

Did the power remain same or not, in either case provide a proof?

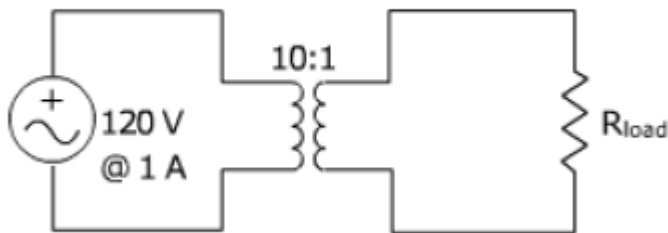

Answer:

$$P_1 = P_2$$

$$P = VI$$

$$V_2 = N_2/N_1 * V_1 = 1/10 * 120 = 12\text{v}$$

SO, the power is not remain same because V_1 is not equal to V_2 .

Question No: 8 (Marks: 5)

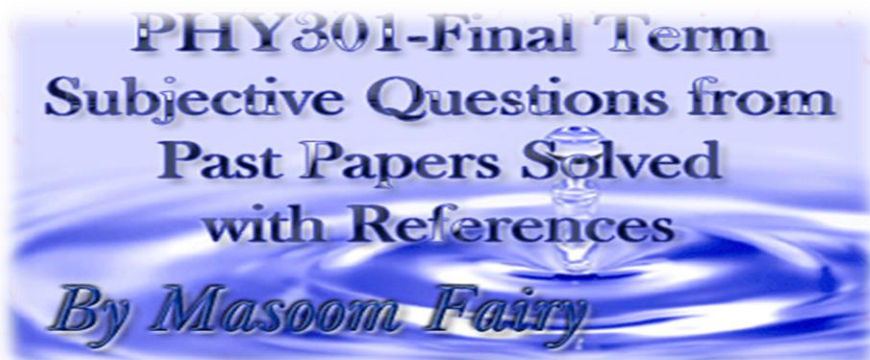

Calculate I_1 , I_2 and I_3 values. Using KVL method.

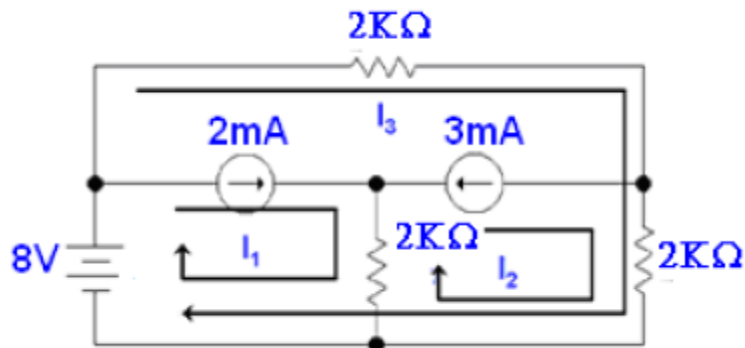

Answer:

$$I_1 = 2\text{mA} \dots \text{Ans}$$

$$I_2 = -3\text{mA} \dots \text{Ans}$$

KVL for loop 3

$$2kI_3 + 2k(I_3 + I_2) = 8$$

$$2kI_3 + 2kI_3 + 2kI_2 = 8$$

$$4kI_3 - 8 = 8$$

$$4kI_3 = 16$$

$$I_3 = 4\text{mA} \dots \text{Ans}$$

Question No: 9 (Marks: 5)

For the circuit shown, find RE & RC

PHY301-Final Term
Subjective Questions from
Past Papers Solved
with References
By Masoom Fairy

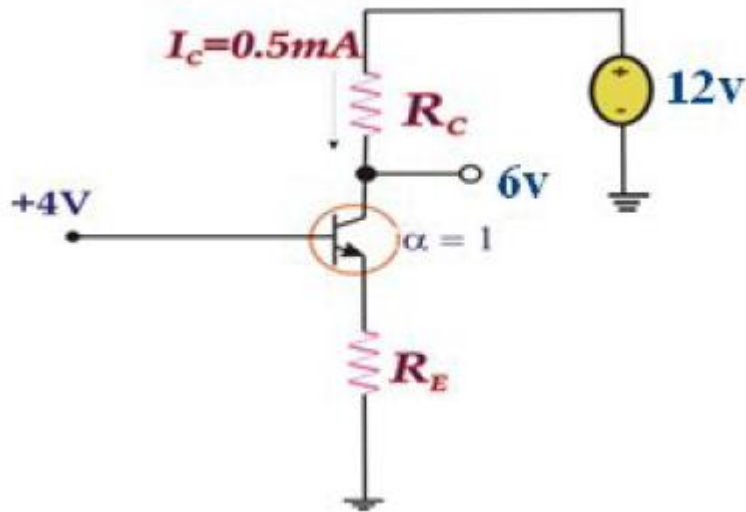

Answer: (According to LECTURE 45 (Example 2))

$I_C = 0.5\text{mA}$ and $\alpha = 1$
 $V_{cb} = 2\text{V}$
 $(12-6)/0.5\text{mA}$
 $R_C = 0\text{k}\Omega = \text{Ans.}$

If $\alpha = 1$. Then
 $I_C = I_E = 0.5\text{mA}$
 $4-0.7/0.5$
 $R_E = 2.6\text{k}\Omega = \text{Ans.}$

Question No: 10 (Marks: 5)

A particular diode, for which $n=1$, is found to conduct 3mA with a junction voltage of 0.7V to 0.8V . Find diode current.

Answer: (Page 142)

$I_D = I_{se} V_d / nV_t$
 If $I_D = 3 \times 10^{-3} \text{A}$
 when $V_d = 0.7$
 then $3 \times 10^{-3} = I_{se} 0.7 / 25.2 \times 10^{-3}$

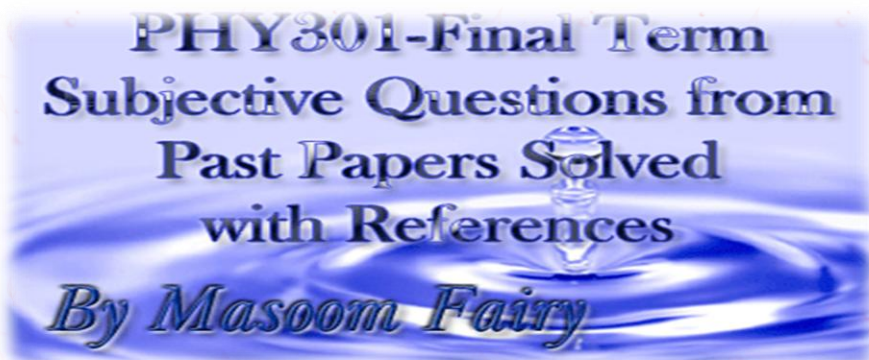

$$= I_s = 2.5905 \times 10^{-15}$$

when $V_d = 0.7$ $I_d = 4.4619 \text{ mA}$

when $V_d = 0.8$ $I_d = 0.15868 \text{ mA}$

Question No: 11 (Marks: 10)

Design the circuit in the fig. so that $V_0 = 3\text{V}$ when $I_L = 0$, and V_0 changes by 40mV per 1mA of load current. Find the value of R . (assume four diodes are identical) relative to a diode with 0.7V drop at 1mA current. Assume $n = 1$

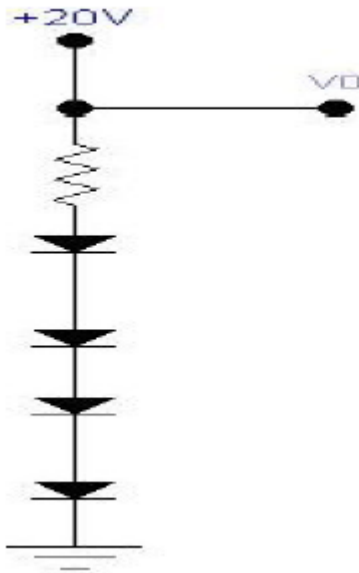

Answer: (PAGE 143)

PHY301-Final Term
Subjective Questions from
Past Papers Solved
with References
By Masoom Fairy

$V_0 = 3V$, when $I_L = 0$, therefore each diode should exhibit a drop of $0.75V$. If $I_L = 1mA$, then V_0 changes by $40mV$ and a change due to each diode is $10mV$.

Hence

$$r_d = 10mV/1mA \\ = 10 \text{ Ohms}$$

but

$$r_d = nV_T/I_D \\ 10 = 1 \times 25m/I_D \\ I_D = 2.5mA$$

Hence

$$15 - 3 - I_D R_D = 0 \\ R = (15 - 3)/I_D \\ = (15 - 3)/2.5m \\ = 4.8k \text{ Ohms.}$$

رہی تعلیم مشرق میں، نہ مغرب میں رہی غیرت
یہ جتنے پڑھتے جاتے ہیں، جہالت بڑھتی جاتی ہے!

PHY301-Final Term
Subjective Questions from
Past Papers Solved
with References
By Masoom Fairy